

Automatic Door Systems



IW-3
Swing Door

使用說明

OPERATION INSTRUCTION



<http://www.kth-automaticdoor.com/>
e-mail : kth@kthtw.com

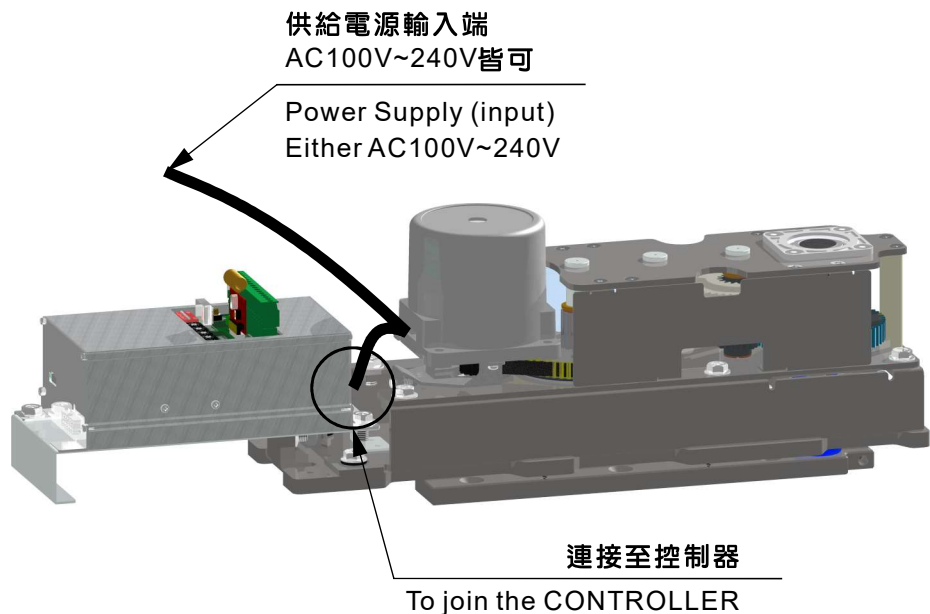

警告

請確認感應器所標示之電壓是否與供給電源相同，若與供給電源電壓不同時，則感應器需另行加裝變壓裝置否則感應器極易燒毀，連接完畢後，請再確認一次。

Warning

Please confirm WHETHER the SENSOR VOLTAGE is the same as the power supply. If different between them, need to add the TRANSFORMER, otherwise the SENSOR would be burned.

本公司另有以下各類自動門配備，請洽本公司各經銷商
Our company has the following series of automatic door, please contact with our distributors/representations.

圓型門 Round type door

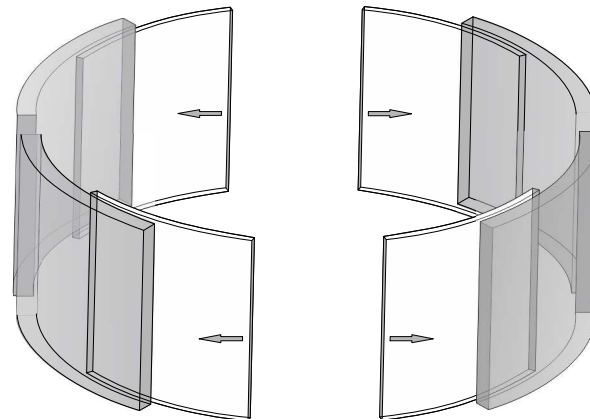

按裝方式請參考圓型門按裝說明

Installation: Please in accordance with the instruction of Round Type Door.

弧形門 Curved type door

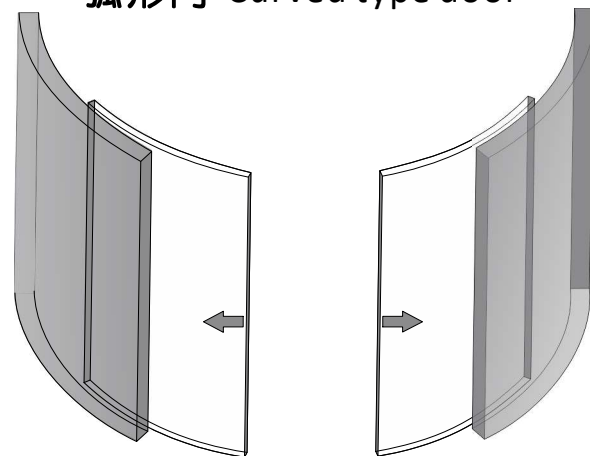

按裝方式請參考弧型門按裝說明

Installation: Please in accordance with the instruction of Curved Type Door.

四扇走雙向門

Telescopic 4-winged Sliding Doors.

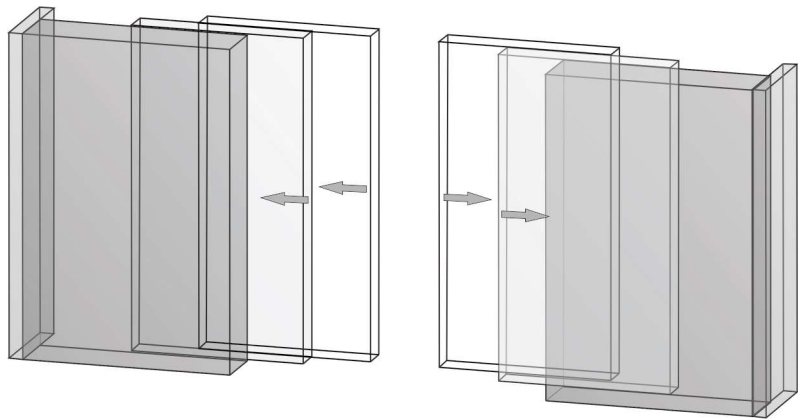

按裝方式請參考四扇走雙向門按裝說明

Installation: Please in accordance with the instruction of Telescopic 4-winged Sliding Doors.

雙扇走單向門

Telescopic 2-winged Sliding Doors.

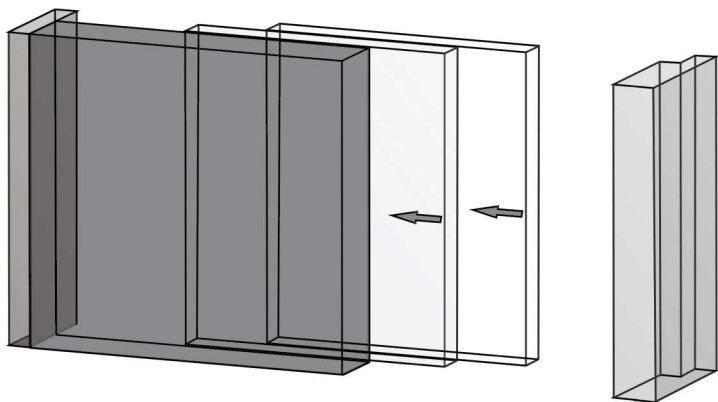

按裝方式請參考雙扇走單向門按裝說明

Installation: Please in accordance with the instruction of Telescopic 2-winged Sliding Doors.

多門互控主從有電鎖

Double Doors with Interlock, Electronic lock, Master/Slave Function

第一組門 1st of Double Door

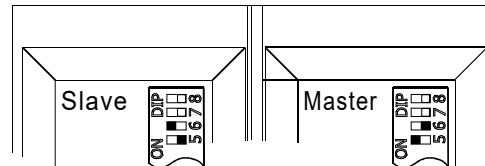

請設定先關門的為主機 (5 ON、6 OFF)
，後關門的為副機 (5 OFF、6 ON)。

Please set the door which closes first
to master (5 NO, 6 OFF) then set the
second to close to slave (5 OFF, 6 ON).

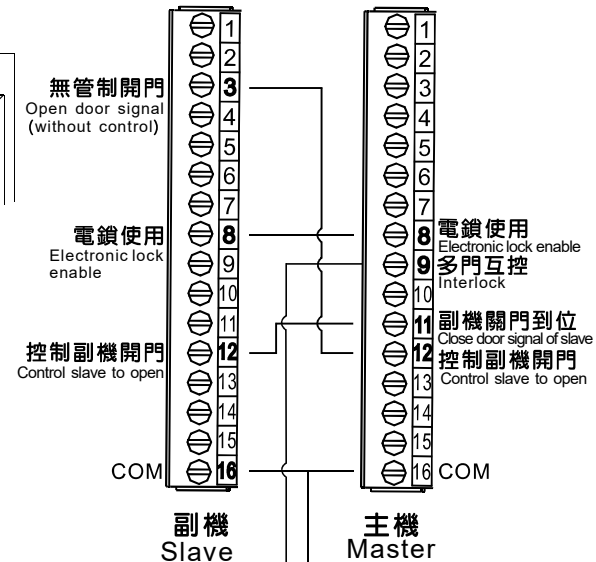

第二組門 2nd of Double Door

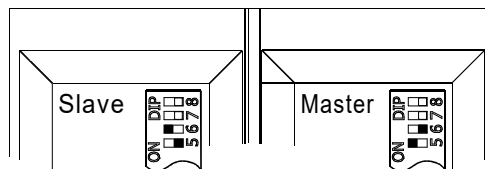

請設定先關門的為主機 (5 ON、6 OFF)
，後關門的為副機 (5 OFF、6 ON)。

Please set the door which closes first
to master (5 NO, 6 OFF) then set the
second to close to slave (5 OFF, 6 ON).

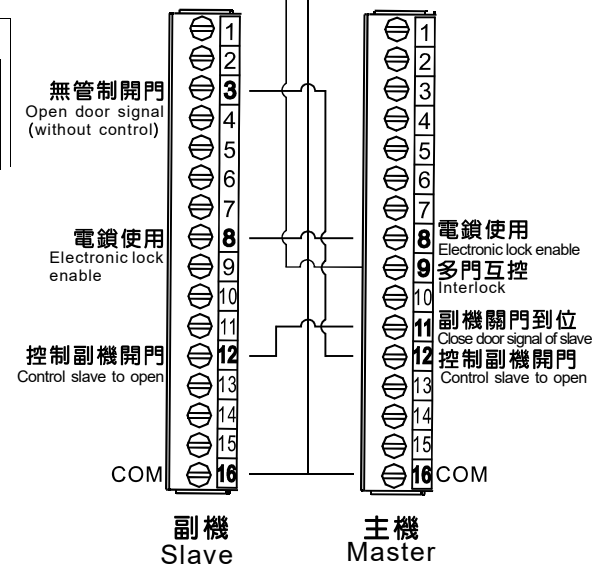

雙門示意圖 Double Door (I)

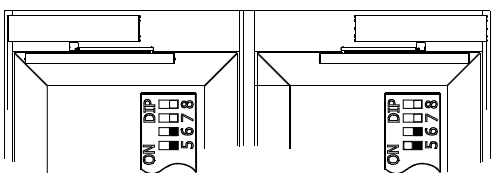

請設定二台主機指撥開關的5、6狀態皆為OFF。

Please set all door (5 OFF, 6 OFF).

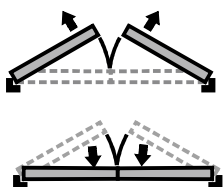

無管制開門
Open door signal
(without control)

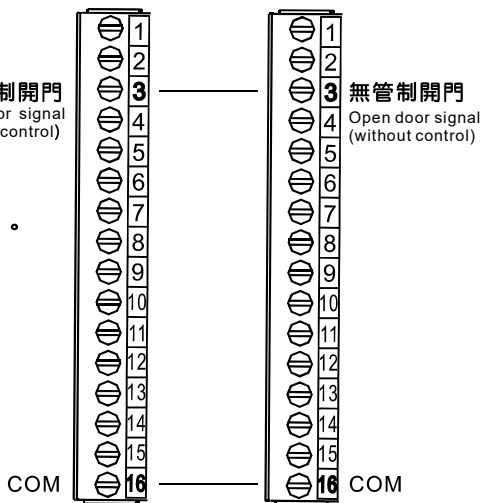

主從有電鎖雙門示意圖 Double Door (II) With Electronic Lock and Master/Slave Function

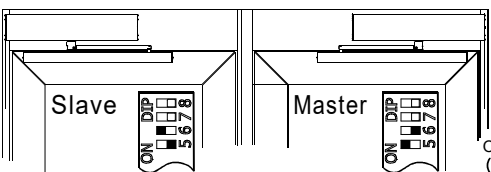

請設定先關門的為主機(5 ON、6 OFF)，後關門的為副機(5 OFF、6 ON)

Please set the door which closes first to master (5 ON, 6 OFF) then set the second to close to slave (5 OFF, 6 ON).

電鎖使用
Electronic lock enable

控制副機開門
Control slave to open

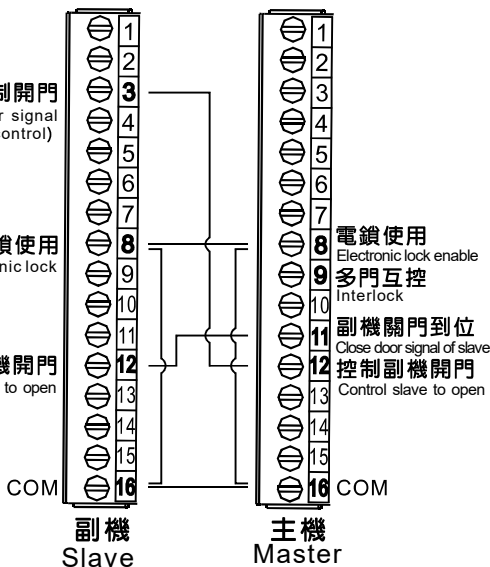
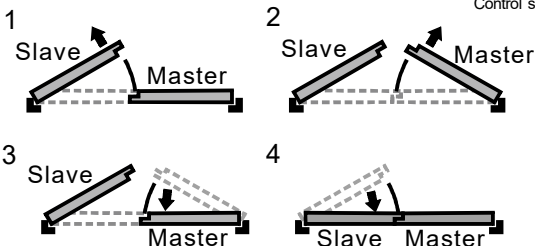

1. 產品規格	TECHNICAL SPECIFICATION.....	P1
2. 門機組各部件說明	DESCRIPTION OF OPERATOR.....	P2
3. 門機組尺寸圖	OPERATOR (SECTION).....	P3
4. 開門幅度設定說明	DISTANCE SETTING.....	P4
5. 各旋鈕功能說明	ADJUST BOARD INSTRUCTION.....	P5
6. 信號連接說明	CONNECTION TO TERMINAL BLOCK.....	P6
7. 雙門/主從關係	DOUBLE DOOR AND MASTER/SLAVE FUNCTION.....	P7
8. 多門互控 (兩道雙門)	INTERLOCK, ELECTRONIC LOCK, MASTER/SLAVE FUNCTION.....	P8
9. 電器連接	CONNECTION.....	P9

型號 MODEL	IW-3
門扇重量/寬度 DOOR WEIGHT & WIDTH	<p>最大值 : ● Max.</p> <p>最小值 : ● Min.</p>
馬達 MOTOR	DC24V 120W 直流無刷馬達 DC24V 120W BRUSHLESS DC MOTOR
控制器 CONTROL	微電腦化處理機控制器 STANDARD MICRO-CONTROL
消耗電量 POWER CONSUMPTION	120W
電源電壓 VOTAGE	AC100V~240V
環境溫度 ENVIRONMENTAL TEMPERATURE	-20°C ~ +50°C
噪音量 VOLUME	最大 55 分貝 55 decibel(max.)
開啟速度 SPEED OF OPENING 90 DEGREE	最大值 : 3 秒 ~ 8 秒 / 90° 3~8 sec. 90° Max.
開啟時間 STARTING TIME	可調 0 秒至 20 秒 0~20 sec. (Regulable)
開門幅度 OPENING DOOR RANGE	依門擋位置而定 DEPENDS ON STOPPERS POSITION
PFC 功率因素 POWER EFFICIENCY	0.95(AC100V全載時) 0.95 (In full load)
手推開啟力量 TRACTION FORCE	2.5 kg

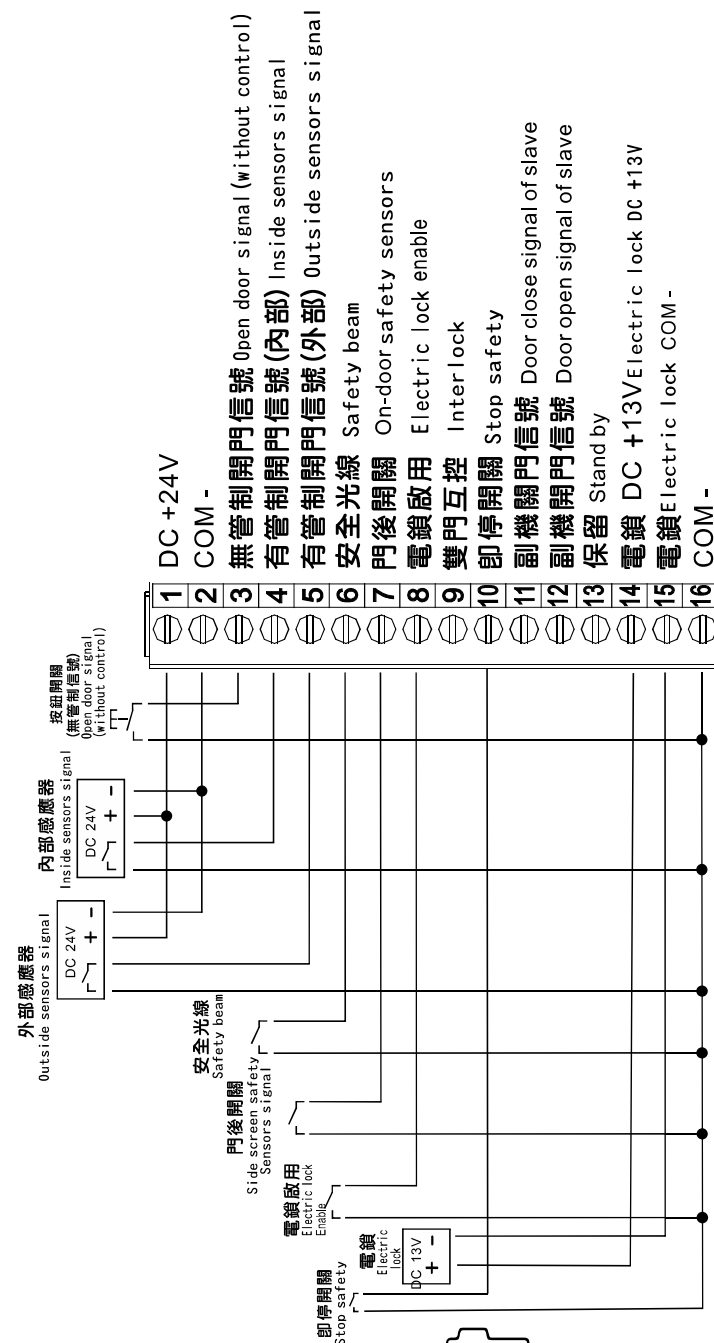

下電鎖時保系統功能自行啟動:停電後再復電後, 門扇先執行關門動作

When connect to electronic lock, the reverse switch will be connected too: after power resumes, the Door-leaf closes the door first.

- 黃 Yellow ● 設定開門幅度：燈亮表示設定行程中
Setting door opening range: When light on you can set the door range.
- 綠 Green ● 燈亮表示信號已輸入
Signal input
- 紅 Red ● 電源指示：燈亮表示電源已接通
Power on

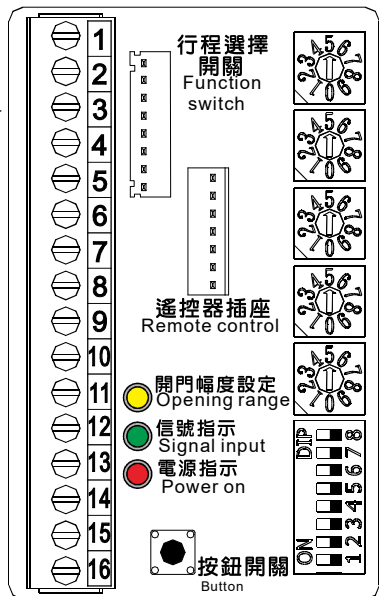

- 開門速度 Opening speed
- 關門速度 Closing speed
- 開門慢速 Opening Slow speed
- 關門慢速 Closing slow speed
- 開門暫停時間 Opening hold time

指撥開關功能敘述 (Fingered switch functions)

8	OFF	關閉防風壓 Wind Pressure Resistance
	ON	開啟防風壓 Wind Pressure Resistance
7	OFF	關門電鎖接點NC Fail-safe (lock, NC.)
	ON	關門電鎖接點NO Fail-secure (lock, NO.)①
6	OFF	不設定為副機 Set to slave-OFF
	ON	設定為副機 Set to slave-ON
5	OFF	不設定為主機 Set to Master- OFF
	ON	設定為主機 Set to Master- ON
4	OFF	無定向功能 Directional Function- OFF
	ON	有定向功能 Directional Function- ON
3	OFF	煞車力量-大 Brake power-Large
	ON	煞車力量-小 Brake power-Little
2	OFF	煞車功能-有(門扇50kg以上) Brake power-ON (over 50 KG.)
	ON	煞車功能-無(門扇50kg以下) Brake power-OFF (under 50 KG.)
1	OFF	開門方向-左開 Opening direction-Left
	ON	開門方向-右開 Opening direction-Right

Note: ① Power to unlock (only continue 5 seconds)

指撥開關 (DIP switch functions)



* 注意：
若為單一門扇時，指撥開關5與6必須設定為 OFF 狀態。

* ATTENTION:
When only use 1unit operator, the pin 5 and pin 6 must set to OFF state.

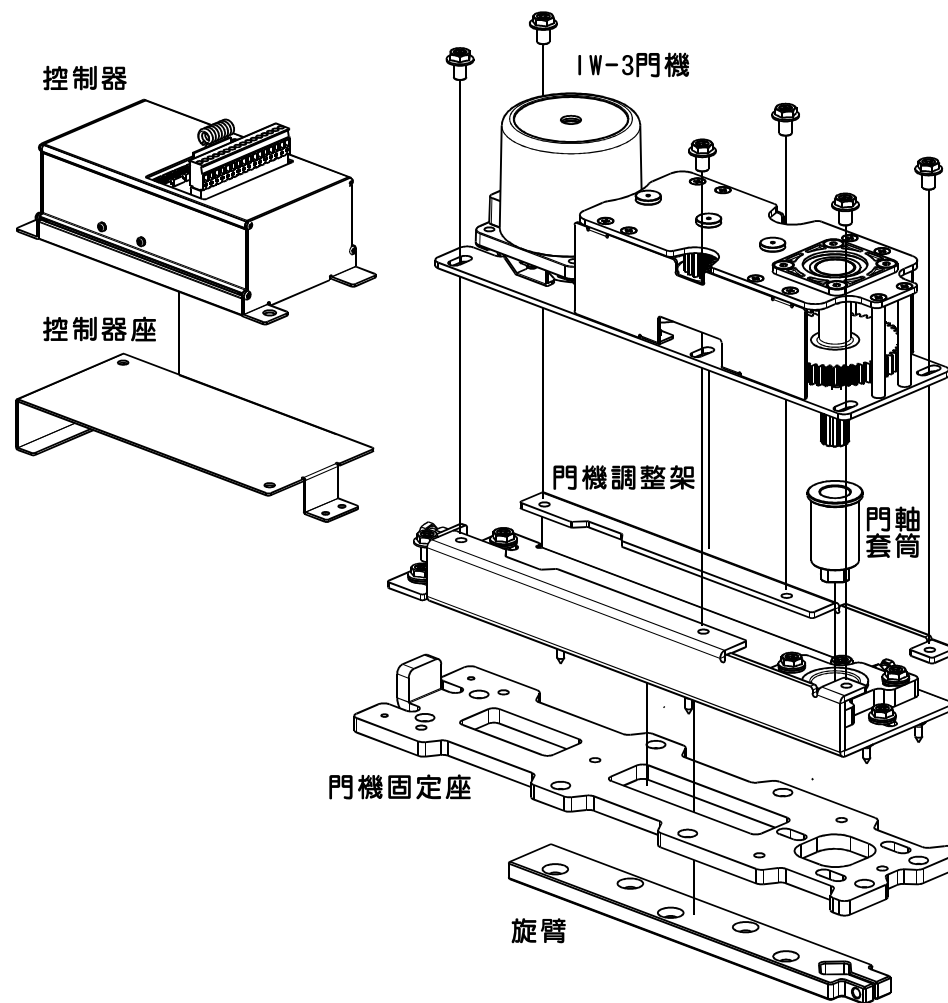

正視圖
Front View

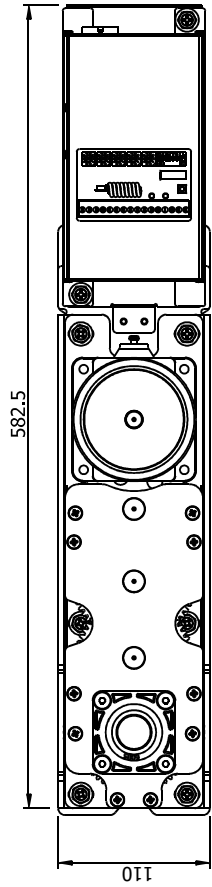

側視圖
Side View

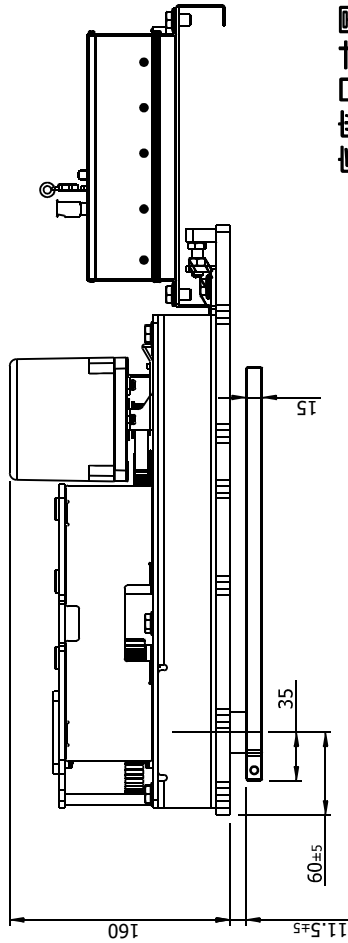
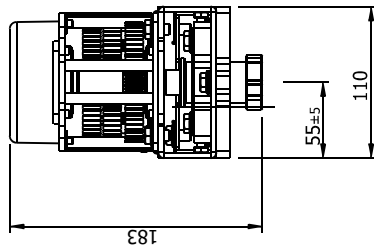

底座尺寸圖
Base Size

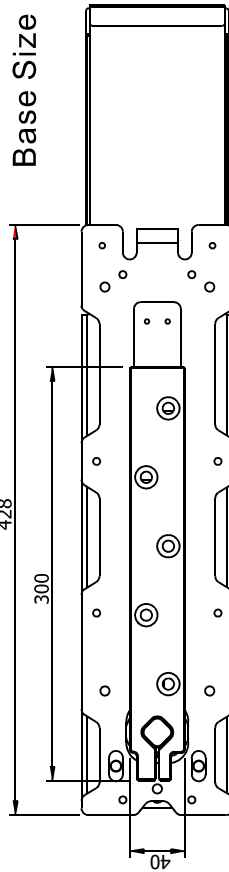

利用門擋器來設定
開門行程

When the yellow light on,
please set the distance of
opening range By stoppers.

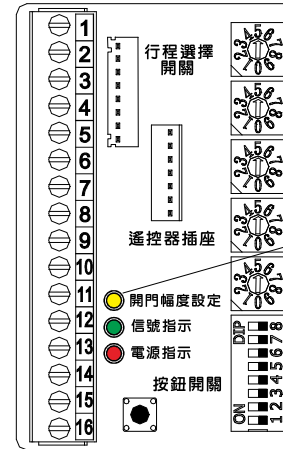
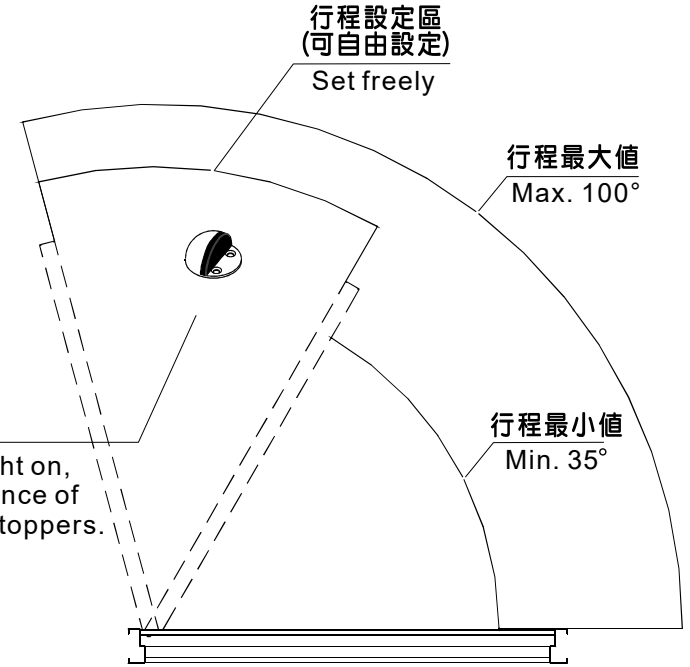

電源開啟後即進入設定行程模式。

When power on the auto start opening range
setting mode.